

ACSL-PF2

Industrial platform

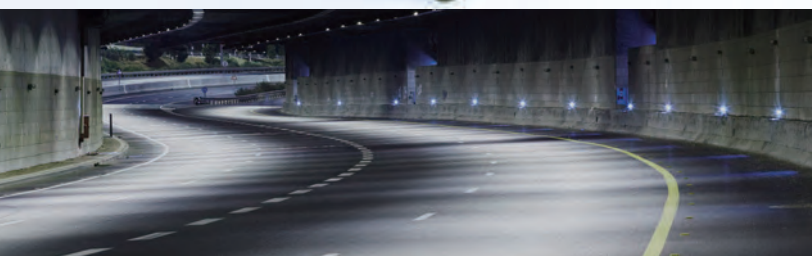

CORE SET

Fully autonomous industrial platform for multiple use-cases

ACSL-PF2 is designed, manufactured, and field-tested to meet a wide range of requirements for a variety of missions. Its unique integrated monocoque structure gives the ACSL-PF2 toughness and resilience to water and dust. ACSL-PF2 has a sealed multi-purpose bay allowing customers to mount their own equipment without sacrificing dust and water ingress protection.



ACSL Industrial Drone Solution

ACSL provides end-to-end industrial drone solutions to increase automation, reduce operational downtime, and free up human resources for more impactful work.



SOLUTION EXAMPLES

SOLUTION 01

Infrastructure Inspection

Precise measurement of position and heading with machine vision technology

Typical drones can only achieve autonomous flight when GPS / GNSS signals are available. However, GPS / GNSS signals are often too weak or unreliable near high structures, under bridges, or indoors. ACSL proprietary algorithms allow the drone to recognize its location and heading from images that it captures from on-board stereo cameras. These cameras also enable that ACSL-PF2 to maintain a controlled distance from objects in sight, a key feature to achieve safe autonomous control in GPS-denied environments.

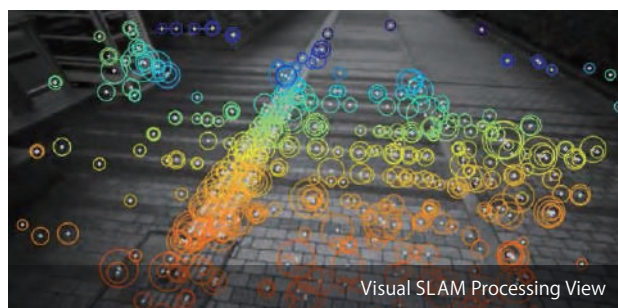

SOLUTION 02

Survey

Exceptional Mapping and Surveying Capability

Capturing high-resolution overlapping images usually limits flight speed, and thereby coverage. ACSL's camera system is designed to achieve both high resolution and sufficient overlap while flying at more than 50 km/h.



SOLUTION 03

Protection

First responder customization

For rescue missions, ACSL-PF2 can carry both a high-resolution camera and an IR camera with real-time video transmission. ACSL's proprietary flight control algorithms achieve outstanding stability in windy conditions.



SOLUTION 04

Delivery

Autonomous parcel delivery system

ACSL-PF2 can transport and deliver packages fully autonomously. A mechanized carrier releases the package automatically upon landing at the delivery point before taking off to return home.



SPECIFICATION

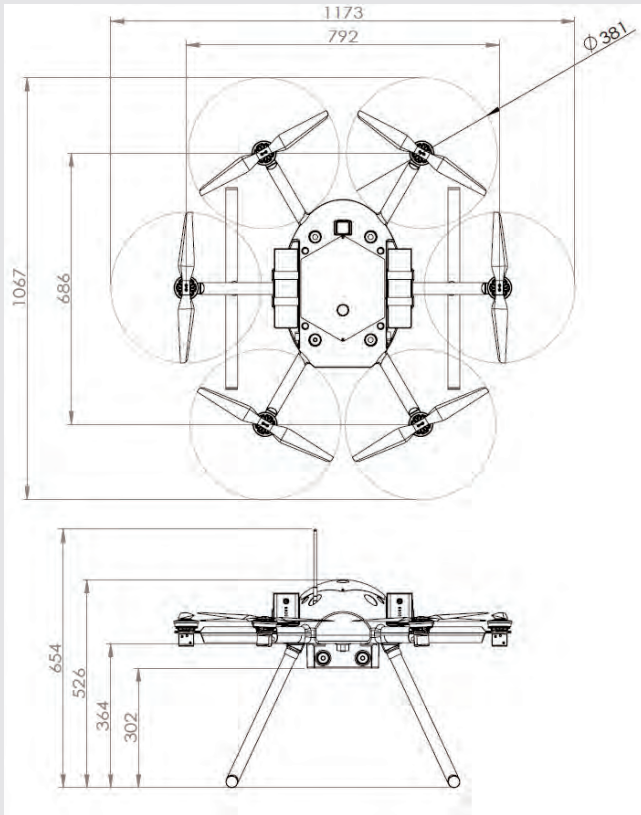

Structure

Width	1,173mm
Height	526mm
Height incl. antenna	654mm
Weight incl. 2 batteries	7.07kg (vehicle only 3.8kg)

Propulsion

Motor	Brushless DC motor Shinanokenshi
Propeller	XOAR (noise reduction) 15inch
ESC	TOSHIBA TPMD0001A

Flight control system

ACSL AP3.0

Battery

Capacity	12,000 mAh x 2
Nominal voltage	22.2V
Battery type	LiPo 6S

Performance

Flight speed	Horizontal : 10m/s Vertical (ascend) : 3m/s Vertical (descend) : 2m/s
Wind resistance	10m/s
Maximum payload	2.75 kg

Options

- Camera gimbal
- Video transmission (5.7GHz, 2.4GHz)
- LTE communication
- Long range 920MHz telemetry link (LoRa)
- Float
- Marker-based landing
- Parachute
- Propeller guard
- Water and dust resistant
- 30x optical zoom camera
- Survey camera
- VisualSLAM for GPS/GNSS-denied environment

*Specification is subject to change without notice

Contact

ACSL (Autonomous Control Systems Laboratory Ltd.), www.acsl.co.jp/en/

Hulic Kasai Rinkai Building 2F, 3-6-4 Rinkaicho, Edogawa-ku, Tokyo134-0086, Japan, TEL +81-3-6661-3870, E-MAIL sales@acsl.co.jp